

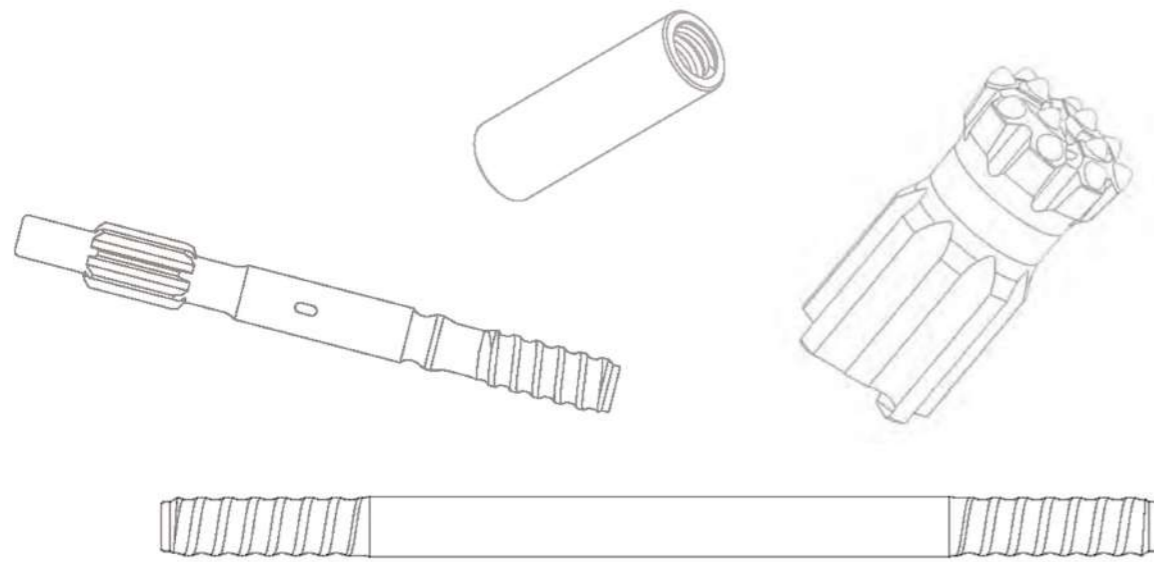

Drilling tool expert

**INDUSTRIAL AND ENGINEERING
TECHNOLOGY Co., Limited**
Add: 8 Floor, China Hong Kong Tower,
8-12 Hennessy Road,
Wan Chai, Hong Kong
E-mail: business@iet-hongkong.com
WhatsApp +852 5473 6914



INDUSTRIAL AND ENGINEERING TECHNOLOGY Co., Limited





Carburizing Furnace Diameter 1 m

Heat Treatment:

Full Carburization + Air Cool Quenching + Tempering

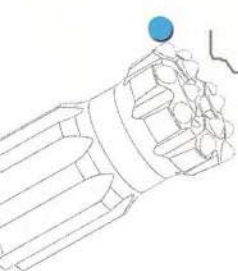

Air cool quenching process significantly improves surface hardness and strength of products together with full carburizing and tempering process give products high toughness.

Heat Treatment Deformation $\leq 2\%$



**INDUSTRIAL AND ENGINEERING
TECHNOLOGY Co., Limited**



Clients offer ideas, we provide solutions.



Our products are used in mines, quarries and construction sites around the world, from the softest to the hardest rocks.

● **Product and Service**





Product Codes

Integral drill rod codes/Tapered drill rod codes

Example: ID-0800-H22-40

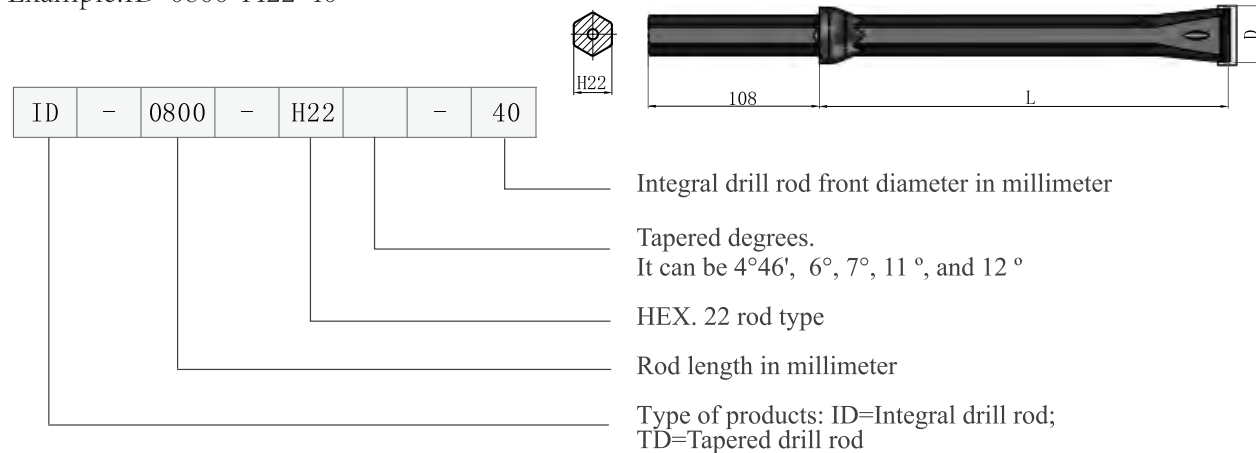

Product Codes

Drill rod codes

Example: MMR38-H32-R32-4305

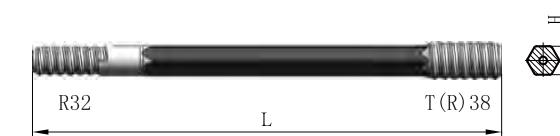
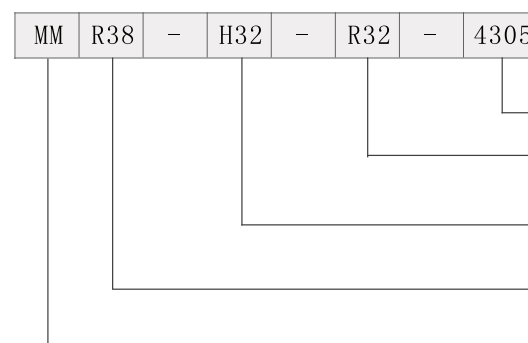

Tapered button bit codes

Example: B32H2207-5927-1P

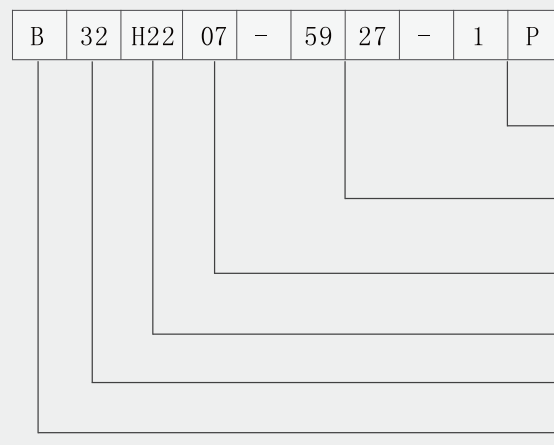

Threaded button bit codes

Example: B89T51-DR813512-4S

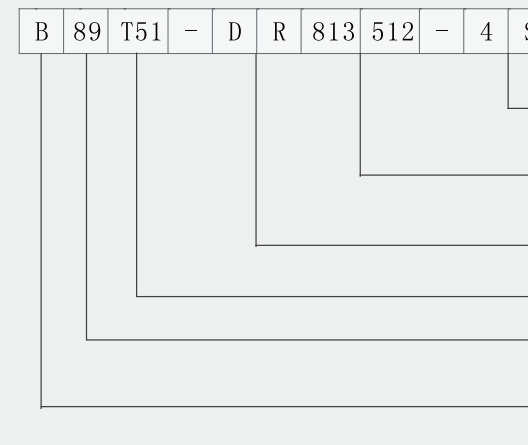

Semi Bridge Coupling

A semi-bridged coupling is best suited for high-torque machines, as it features a small non-threaded bridge in the center of the coupling. This bridge prevents the drill rod from passing through, while the smaller diameter steel end portions fit together in the center bridge area. Most R and T threaded couplings are semi-bridged, providing the best energy transfer.

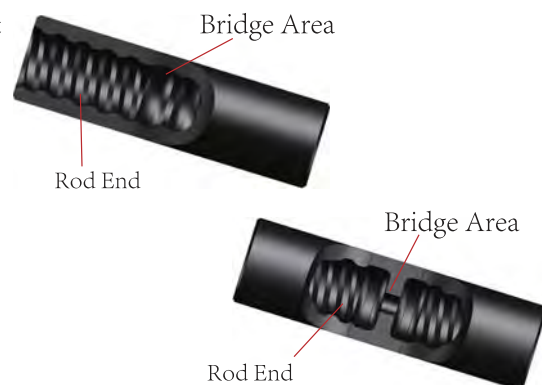

Full Bridge Coupling

This type of coupling is best suited to rigs equipped with independent rotation like S36IR rockdrill, as it eliminates the potential for the coupling to creep along the threaded joints, has better uncoupling characteristics and tends to maintain tighter joints, and has less chance of jamming. It is typically used in surface applications.

Shank adapter codes

Example: COP1838-38T38-525

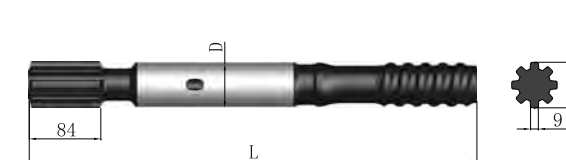
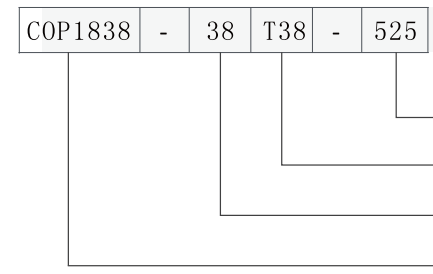

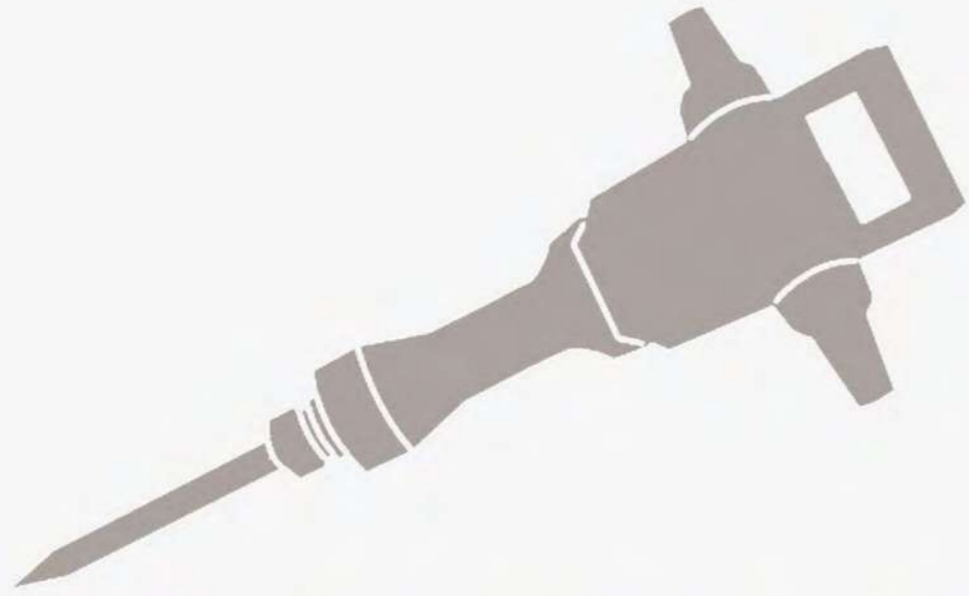

• **Small Hole Drilling**





Small Hole Drilling



Small hole drilling string

Length		Weight		Diameter		Part number
MM	FT IN	KG	LB	MM	IN	

Tapered drill rod, shank H22×108mm, 7°



800	2' 7"	2.7	6.6			TD-0800-H227
1220	4'	4.0	8.9			TD-1220-H227
1600	5' 3"	5.4	11.8			TD-1600-H227
1830	6'	5.9	13.0			TD-1830-H227

4° 46', 6°, 11° and 12° rods with all length are available, Please contact us for more information.

Integral drill rod, shank H22×108mm, Series 12



800	2' 7"	3.0	6.6	40	1 5/8"	ID-0800-H22-40
1600	5' 3"	5.0	11.0	39	1 17/32"	ID-1600-H22-39
2400	7' 10"	7.0	15.4	38	1 1/2"	ID-2400-H22-38
3200	10' 6"	10.0	22.0	37	1 29/54"	ID-3200-H22-37
4000	13' 1"	12.6	27.8	36	1 27/64"	ID-4000-H22-36

Other specifications are available upon your needs. Please contact us for more information.



Small Hole Drilling

Tapered button bit, H22, 7°

Diameter		Button		Flushing	Angle (°)	Weight		Part Number
MM	IN	Front	Gauge			KG	LB	



32	1 1/4"	2*7	5*7	1F2G	35	0.3	0.6	B32H2207-5727-1
35	1 3/8"	2*7	5*8	1F2G	35	0.3	0.7	B35H2207-5827-1
38	1 1/2"	2*7	5*9	1F2G	35	0.3	0.8	B38H2207-5927-1
41	1 5/8"	2*8	5*9	1F2G	35	0.5	1.0	B41H2207-5928-1



32	1 1/4"	2*7	5*7	2F1G	35	0.3	0.6	B32H2207-5727-2
35	1 3/8"	2*7	5*8	2F1G	35	0.3	0.7	B35H2207-5827-2
38	1 1/2"	2*7	5*9	2F1G	35	0.3	0.8	B38H2207-5927-2
41	1 5/8"	2*8	5*9	2F1G	35	0.5	1.0	B41H2207-5928-2

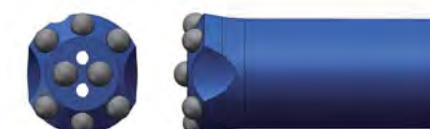

32	1 1/4"	2*7	6*7	2F1G	35	0.3	0.6	B32H2207-6727-2
36	1 7/16"	2*7	6*7	2F1G	35	0.3	0.7	B36H2207-6727-2
38	1 1/2"	2*7	6*8	2F1G	35	0.3	0.8	B38H2207-6827-2
40	1 37/64"	2*8	6*8	2F1G	35	0.4	0.9	B40H2207-6828-2

4°46', 6°, 11°, 12° bits are available with the designs above and other specifications are available upon your needs. Please contact us for more information.



- **Drifting and Tunneling**

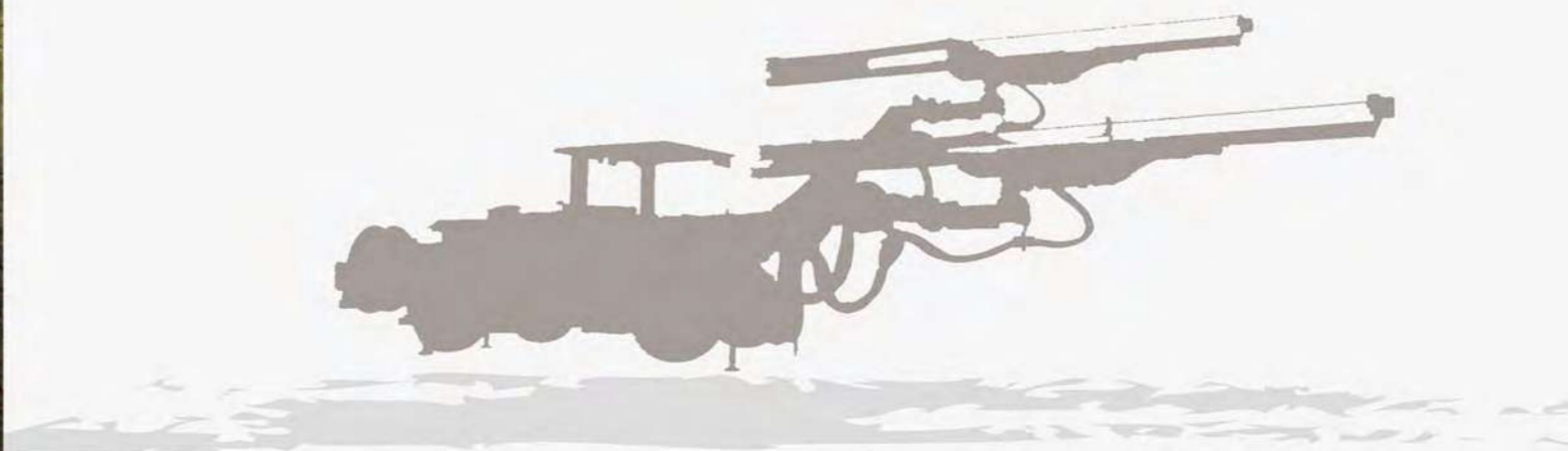



Drifting And Tunneling

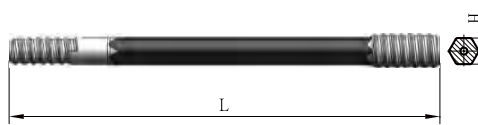

Drifting and tunneling drilling string

Products	Length			Weight		Part number
	MM	FT	IN	KG	LB	
R32-R25 and R32-R28 drill rod 	1870	6'	1 5/8"	6.9	15.2	MMR32-H25-R25-1870
	2175	7'	1 5/8"	8.4	18.5	MMR32-H25-R25-2175
	2475	8'	1 1/2"	9.5	20.9	MMR32-H25-R25-2475
	2785	9'	1 5/8"	11	24.2	MMR32-H25-R25-2785
	3090	10'	1 5/8"	12	26.4	MMR32-H25-R25-3090
	3700	12'	1 5/8"	14	30.8	MMR32-H25-R25-3700
	2785	9'	1 5/8"	13.8	30.4	MMR32-H28-R25-2785 MMR32-H28-R28-2785
	3090	10'	1 5/8"	15.3	33.7	MMR32-H28-R25-3090 MMR32-H28-R28-3090
	3700	12'	1 5/8"	18.9	41.6	MMR32-H28-R25-3700 MMR32-H28-R28-3700
	4005	13'	1 1/2"	19.9	43.8	MMR32-H28-R25-4005 MMR32-H28-R28-4005
	4305	14'	1 1/2"	21.3	46.9	MMR32-H28-R25-4305 MMR32-H28-R28-4305

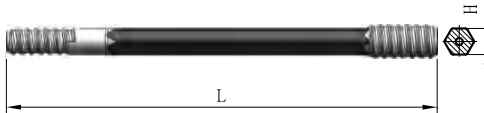

Drifting And Tunneling

Products	Length			Weight		Part number
	MM	FT	IN	KG	LB	
T38/R38-R32 drill rod 	3090	10'	1 5/8"	19.1	42	MMR38-H32-R32-3090 MMT38-H32-R32-3090
	3090	10'	1 5/8"	23.1	51	MMR38-H35-R32-3090 MMT38-H35-R32-3090
	3700	12'	1 1/2"	23.5	51.9	MMR38-H32-R32-3700 MMT38-H32-R32-3700
	3700	12'	1 1/2"	27.9	61.6	MMR38-H35-R32-3700 MMT38-H35-R32-3700
	4305	14'	1 1/2"	27.4	60.3	MMR38-H32-R32-4305 MMT38-H32-R32-4305
	4305	14'	1 1/2"	32.9	72.5	MMR38-H35-R32-4305 MMT38-H35-R32-4305
	4915	16'	1 1/2"	30.2	66.6	MMR38-H32-R32-4915 MMT38-H32-R32-4915
	4915	16'	1 1/2"	37	81.6	MMR38-H35-R32-4915 MMT38-H35-R32-4915
	5525	18'	1 1/2"	34.2	75.1	MMR38-H32-R32-5525 MMT38-H32-R32-5525
	5525	18'	1 1/2"	42.4	93.5	MMR38-H35-R32-5525 MMT38-H35-R32-5525
	4305	14'	1 1/2"	34	74.8	MMT38-D38-R35-4305
	4305	14'	1 1/2"	32.9	72.5	MMT38-H35-R35-4305
	4915	16'	1 1/2"	39	85.8	MMT38-D38-R35-4915
	4915	16'	1 1/2"	37	81.6	MMT38-H35-R35-4915
	5525	18'	1 1/2"	44	96.8	MMT38-D38-R35-5525
5525	18'	1 1/2"	42.4	93.5	MMT38-H35-R35-5525	
6135	20'	1 1/2"	48.5	107	MMT38-D38-R35-6135	
6135	20'	1 1/2"	48.2	106	MMT38-H35-R35-5525	







Drifting And Tunneling

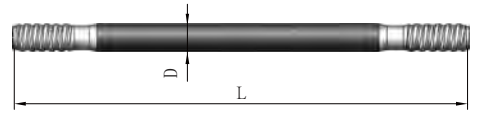

Drifting And Tunneling

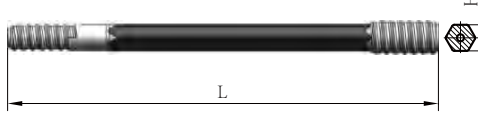
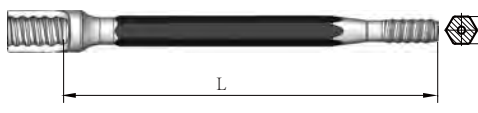
Coupler and bit adapter

Products	Length			Weight		Part number
	MM	FT	IN	KG	LB	
T35-R35/T35 MM drill rod 	3090	10'	1 5/8"	25	55	MMT35-D38-R35-3090
	3090	10'	1 5/8"	25	55	MMT35-D38-T35-3090
	3700	12'	1 1/2"	32	70.4	MMT35-D38-R35-3700
	3700	12'	1 1/2"	32	70.4	MMT35-D38-T35-3700
T35-R35/T35 MF drill rod/Speed rod 	4305	14'	1 1/2"	35	77	MFT35-D38-R35-4305
	4305	14'	1 1/2"	35	77	MFT35-D38-T35-4305
	4915	16'	1 1/2"	40	88	MFT35-D38-R35-4915
	4915	16'	1 1/2"	40	88	MFT35-D38-T35-4915
	5525	18'	1 1/2"	45	99	MFT35-D38-R35-5525
	5525	18'	1 1/2"	45	99	MFT35-D38-T35-5525
	6135	20'	1 1/2"	50	110	MFT35-D38-R35-6135
	6135	20'	1 1/2"	50	110	MFT35-D38-T35-6135
T38-R32 MM drill rod 	3090	10'	1 5/8"	26.5	58.4	MMT38-H32-R32-3090
	3700	12'	1 1/2"	30	66.1	MMT38-H32-R32-3700
T38-R32 MF drill rod/Speed rod 	4305	14'	1 1/2"	32.9	72.5	MFT38-H32-R32-4305
	4915	16'	1 1/2"	39.6	87.3	MFT38-H32-R32-4915
	5525	18'	1 1/2"	44.7	98.5	MFT38-H32-R32-5525
	6135	20'	1 1/2"	51.3	113	MFT38-H32-R32-6135

Products	Length		Weight		Part number
	MM	IN	KG	LB	
	160	6 1/4"	0.7	1.5	C3516-R25/R25
	150	5 29/32"	0.9	2	C4415-R32/R32
	170	6 3/4"	1.8	4	C5517-R38/R38
	190	7 1/2"	2	4.4	C5519-T38/T38
	190	7 1/2"	2	4.4	C5519-T38/R35
	190	7 1/2"	2	4.4	C5519-T38/R32
	225	8 55/64"	2.3	5.1	C5522-FT38/MR32
	225	8 55/64"	2.3	5.1	C5522-FR38/MR32



Drifting And Tunneling

R25 drill bit

Diameter		Button		Flushing	Angle (°)	Weight		Part Number
MM	IN	Front	Gauge			KG	LB	



38	1 1/2"	2*7	5*9	1F2G	35	0.5	1.1	B38R25-5927-1
41	1 5/8"	2*8	5*9	1F2G	35	0.6	1.3	B41R25-5928-1
43	1 11/16"	2*9	5*9	1F2G	35	0.7	1.5	B43R25-5929-1
45	1 3/4"	2*9	5*10	1F2G	35	0.9	2.0	B45R25-51029-1
51	2"	2*10	5*11	1F2G	35	1.0	2.2	B51R25-511210-1



38	1 1/2"	2*7	5*9	2F1G	35	0.5	1.1	B38R25-5927-2
41	1 5/8"	2*8	5*10	2F1G	35	0.6	1.3	B41R25-51028-S
43	1 11/16"	2*9	5*10	2F1G	35	0.7	1.5	B43R25-51029-2
45	1 3/4"	2*8	5*11	2F1G	35	0.9	2.0	B45R25-51128-2



43	1 11/16"	3*8	6*9	3F1G	35	0.7	1.5	B43R25-6938-3
45	1 3/4"	3*8	6*9	3F1G	35	0.9	2.0	B45R25-6938-3
48	1 7/8"	3*9	6*10	3F1G	35	0.9	2.0	B48R25-61039-3
51	2"	3*9	6*10	3F1G	35	1.0	2.2	B51R25-61039-3



Drifting And Tunneling

R28 drill bit

Diameter		Button		Flushing	Angle (°)	Weight		Part Number
MM	IN	Front	Gauge			KG	LB	



38	1 1/2"	2*7	5*9	1F2G	35	0.5	1.1	B38R28-5927-1
41	1 5/8"	2*8	5*9	1F2G	35	0.6	1.3	B41R28-5928-1
43	1 11/16"	2*9	5*9	1F2G	35	0.7	1.5	B43R28-5929-1
45	1 3/4"	2*9	5*10	1F2G	35	0.9	2	B45R28-51029-1
51	2"	2*10	5*11	1F2G	35	1	2.2	B51R28-511210-1



38	1 1/2"	2*7	5*9	2F1G	35	0.5	1.1	B38R28-5927-2
41	1 5/8"	2*8	5*10	2F1G	35	0.6	1.3	B41R28-51028-S
43	1 11/16"	2*9	5*10	2F1G	35	0.7	1.5	B43R28-51029-2
45	1 3/4"	2*8	5*11	2F1G	35	0.9	2	B45R28-51128-2



43	1 11/16"	3*8	6*9	3F1G	35	0.7	1.5	B43R28-6938-3
45	1 3/4"	3*8	6*9	3F1G	35	0.9	2.0	B45R28-6938-3
48	1 7/8"	3*9	6*10	3F1G	35	0.9	2.0	B48R28-61039-3
51	2"	3*9	6*10	3F1G	35	1.0	2.2	B51R28-61039-3



Drifting And Tunneling

R32 drill bit

Diameter		Button		Flushing	Angle (°)	Weight		Part Number
MM	IN	Front	Gauge			KG	LB	



41	1 5/8"	2*8	5*9	1F2G	35	0.6	1.3	B41R32-5928-1
43	1 11/16"	2*9	5*9	1F2G	35	0.7	1.5	B43R32-5929-1
45	1 3/4"	2*9	5*10	1F2G	35	0.9	2	B45R32-51029-1
48	1 7/8"	2*9	5*10	1F2G	35	0.9	2	B48R32-51029-1
51	2"	2*10	5*11	1F2G	35	1	2.2	B51R32-511210-1



43	1 11/16"	2*8	6*9	2F1G	35	0.7	1.5	B43R32-6928-2
45	1 3/4"	2*9	6*9	2F1G	35	0.9	2	B45R32-6929-2
48	1 7/8"	2*9	6*10	2F1G	35	0.9	2	B48R32-61029-2
51	2"	2*10	6*11	2F1G	35	1	2.2	B51R32-611210-2



43	1 11/16"	3*8	6*9	3F1G	35	0.7	1.5	B43R32-6938-3
45	1 3/4"	3*8	6*9	3F1G	35	0.9	2	B45R32-6938-3
48	1 7/8"	3*8	6*9	3F1G	35	0.9	2.0	B48R32-6938-3
51	2"	3*9	6*10	3F1G	35	1.0	2.2	B51R32-61039-3
57	2 1/4"	3*10	6*11	3F1G	35	1.2	2.6	B57R32-611310-3
64	2 1/2"	3*11	6*12	3F1G	35	1.6	3.5	B64R32-612311-3



Drifting And Tunneling

R35 drill bit

Diameter		Button		Flushing	Angle (°)	Weight		Part Number
MM	IN	Front	Gauge			KG	LB	



43	1 11/16"	3*8	6*9	3F1G	35	0.7	1.5	B43R35-6938-3
45	1 3/4"	3*8	6*9	3F1G	35	0.9	2	B45R35-6938-3
48	1 7/8"	3*9	6*10	3F1G	35	0.9	2	B48R35-61039-3
51	2"	3*9	6*10	3F1G	35	1	2.2	B51R35-61039-3
51	2"	3*9	6*10	3F1G	35	1	2.3	B54R35-61039-3
51	2"	3*11	6*12	3F1G	35	1	3.5	B64R35-612311-3



Drifting And Tunneling

R25, R28, R32 and R35 reaming tools/Hole openers

Diameter		Button		Flushing	Angle (°)	Weight		Part Number
MM	IN	Front	Gauge			KG	LB	



26	1 1/32"	-	-	4	-	1.4	3.1	PA26R25-6
26	1 1/32"	-	-	4	-	1.4	3.1	PA26R28-6
26	1 1/32"	-	-	4	-	1.4	3.1	PA26R32-6
40	1 37/64"	-	-	4	-	2.8	6.2	PA40R32-12
40	1 37/64"	-	-	4	-	2.8	6.2	PA40R35-12

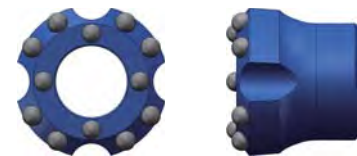

64	2 1/2"	4*8	8*9	-	25	0.9	2	CB64-6
76	3"	4*10	8*10	-	30	1.4	3.1	CB76-6
89	3 1/2"	4*10	8*12	-	35	1.8	4	CB89-6
89	3 1/2"	4*10	8*12	-	35	1.8	4	CB89-12
102	4"	4*13	8*13	-	35	2.4	5.3	CB102-12
127	5"	8*13	8*13	-	35	3.8	8.4	CB127-12



Drifting And Tunneling

R25, R28, R32 and R35 reaming tools/Hole openers

Diameter		Button		Flushing	Angle (°)	Weight		Part Number
MM	IN	Front	Gauge			KG	LB	



89	3 1/2"	4*10	8*12	4	35	3	6.6	RB89/43R32
102	4"	3*10	12*13	4	35	4.2	9.3	RB102/43R32
89	3 1/2"	4*10	8*12	4	35	3	6.6	RB89/43R35
102	4"	3*10	12*13	4	35	4.2	9.3	RB102/43R35

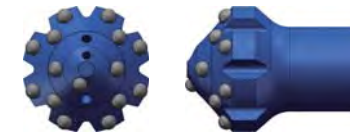

76	3"	4*10	8*10	2	35	2	4.4	DB76R32
89	3 1/2"	4*10	8*12	2	35	2.6	5.7	DB89R32
102	4"	3*10	12*13	2	35	4.2	9.3	DB102R32
102	4"	3*10	12*13	2	35	4.2	9.3	DB102R35



- **Surface Drilling**

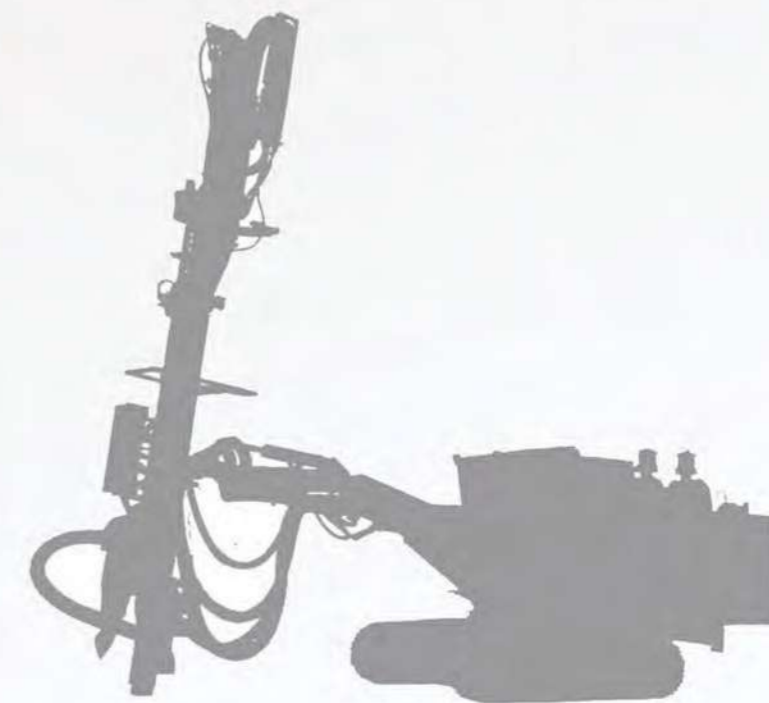



Surface Drilling

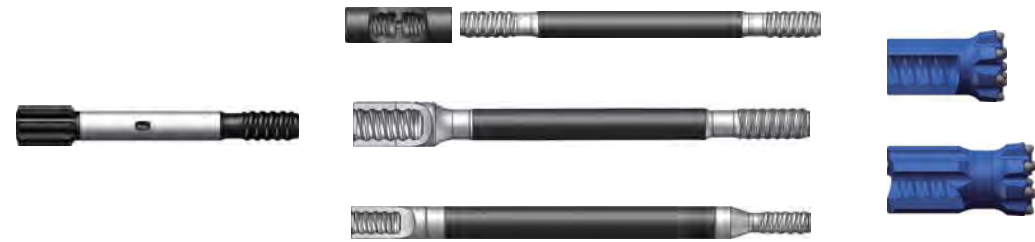

Surface drilling string

T38, T45, T51, GT60 and EL60 Guide tube and drill rod

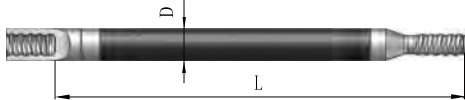
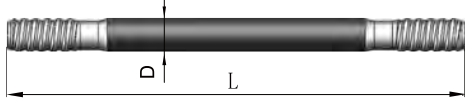

Products	Length			Weight		Part number
	MM	FT	IN	KG	LB	
Guide Tube 	3660	12'		51	112	GT38-D56-T38-3660
	3660	12'		46	101	GT45-D64-T45-3660
	3660	12'		78	172	GT45-D76-T45-3660
	3660	12'		76	167	GT51-D76-T51-3660
	3660	12'		89	196	GT51-D89-T51-3660
Drill rod 	3050	10'		24.8	54.6	MMT38-D38-T38-3050
	3660	12'		29	63.8	MMT38-D38-T38-3660
	3050	10'		35	77	MMT45-D45-T45-3050
	3660	12'		42	92.4	MMT45-D45-T45-3660
	4265	14'		49	108	MMT45-D45-T45-4265
	3050	10'		43.3	95.3	MMT51-D51-T51-3050
	3660	12'		52	114	MMT51-D51-T51-3660
4265	14'		60	132	MMT51-D51-T51-4265	



Surface Drilling

Products	Length			Weight		Part number
	MM	FT	IN	KG	LB	
	3050	10'		26	57.2	MFT38-D38-T38-3050
	3660	12'		32	70.4	MFT38-D38-T38-3660
	3050	10'		38	83.6	MFT45-D45-T45-3050
	3660	12'		44	96.8	MFT45-D45-T45-3660
	4265	14'		52	114	MFT45-D45-T45-4265
	3660	12'		56	123	MFT51-D51-T51-3660
	4265	14'		64	141	MFT51-D51-T51-4265
	6095	20'		91.5	201	MFT51-D51-T51-6095
	3660	12'		73	161	MFGT60-D60-GT60-3660
	4265	14'		86	189	MFGT60-D60-GT60-4265
	6095	20'		120	264	MFGT60-D60-GT60-6095
	3660	12'		73	161	MFEL60-D60-EL60-3660
	4265	14'		86	189	MFEL60-D60-EL60-4265
	6095	20'		120	264	MFEL60-D60-EL60-6095

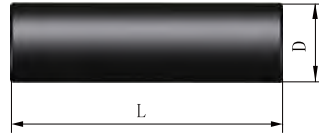
T38, T45 and T51 Coupler and bit adapter

Products	Length	Weight		Part number
	MM	KG	LB	
	190	2	4.4	C5519-T38/T38
	210	2.8	6.2	C5521-T45/T45
	225	4.7	10.3	C7122-T51/T51
	265	2.9	6.4	C6426-FT45/MT38
	285	3.8	8.4	C7128-FT51/MT45



Surface Drilling

T38 Button bit

Diameter		Button		Flushing	Angle (°)	Weight		Part Number
MM	IN	Front	Gauge			KG	LB	



64	2 1/2"	3*11	6*12	3FIG	35	1	2.2	B64T38-612311-3
64	2 1/2"	4*10	8*11	2FIG	35	1.6	3.5	B64T38-811410-2
76	3"	3*12	6*12	3FIG	35	1.6	3.5	B76T38-612312-3
76	3"	4*12	8*12	2FIG	35	2.4	5.3	B76T38-812412-2
76	3"	5*11	8*12	4FOG	35	2.4	5.3	B76T38-812511-4
89	3 1/2"	5*12	8*12	4FOG	35	3.2	7	B89T38-812512-4

RETRAC



64	2 1/2"	3*11	6*12	3FIG	35	1.6	3.5	B64T38-R612311-3
64	2 1/2"	4*10	8*11	2FIG	35	1.8	4	B64T38-R811410-2
76	3"	3*12	6*12	3FIG	35	1.6	3.5	B76T38-R612312-3
76	3"	4*12	8*12	2FIG	35	2.6	5.7	B76T38-R812412-2
76	3"	5*11	8*12	4FOG	35	2.6	5.7	B76T38-DR812511-4
89	3 1/2"	5*12	8*12	4FOG	35	3.5	7.7	B89T38-DR812512-4



Surface Drilling

T45 Button bit

Diameter		Button		Flushing	Angle (°)	Weight		Part Number
MM	IN	Front	Gauge			KG	LB	

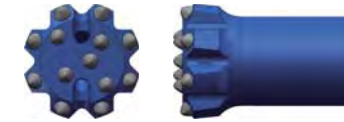

76	3"	5*11	8*12	4FOG	35	2.4	5.3	B76T45-D812511-4
76	3"	6*10	8*11	2FIG	35	2.4	5.3	B76T45-811610-2
89	3 1/2"	5*12	8*12	4FOG	35	3.2	7	B89T45-D812512-4
89	3 1/2"	6*10	9*11	3FIG	35	4.4	9.7	B89T45-911610-3
102	4"	9*11	9*13	3FOG	35	7	15.4	B102T45-913911-3

RETRAC



76	3"	5*11	8*12	4FOG	35	2.6	5.7	B76T45-DR812511-4
76	3"	6*10	8*11	2FIG	35	2.6	5.7	B76T45-R811610-2
89	3 1/2"	5*12	8*12	4FOG	35	3.5	7.7	B89T45-DR812512-4
89	3 1/2"	6*10	9*11	3FIG	35	4.6	10.1	B89T45-R911610-3
102	4"	9*11	9*13	3FOG	35	7.3	16.1	B102T45-R913911-3



Surface Drilling

T51 Button bit

Diameter		Button		Flushing	Angle (°)	Weight		Part Number
MM	IN	Front	Gauge			KG	LB	



89	3 1/2"	5*12	8*12	4FOG	35	3.2	7	B89T51-D812512-4
89	3 1/2"	6*10	9*11	3F1G	35	4.4	9.7	B89T51-911610-3
102	4"	6*12	9*12	3F1G	35	7	15.4	B102T51-912612-3
102	4"	9*11	9*13	3FOG	35	4.6	10.4	B102T51-913911-3
115	4 1/2"	10*12	9*14	3FOG	35	6	13.2	B115T51-9141012-3
127	5"	10*13	9*14	3FOG	35	6.6	14.5	B127T51-9141013-3

RETRAC



89	3 1/2"	5*12	8*12	4FOG	35	3.5	7.7	B89T51-DR812512-4
89	3 1/2"	6*10	9*11	3F1G	35	4.7	10.3	B89T51-R911610-3
102	4"	6*12	9*12	3F1G	35	7.5	16.5	B102T51-R912612-3
102	4"	9*11	9*13	3FOG	35	7	15.4	B102T51-R913911-3
115	4 1/2"	10*12	9*14	3FOG	35	8.5	18.7	B115T51-R9141012-3
127	5"	10*13	9*14	3FOG	35	12	26.4	B127T51-R9141013-3



Surface Drilling

GT60 Button bit

Diameter		Button		Flushing	Angle (°)	Weight		Part Number
MM	IN	Front	Gauge			KG	LB	



92	3 5/8"	6*12	8*14	4FOG	35	5.2	11.4	B92GT60-D814612-4
102	4"	9*11	9*13	3FOG	35	7	15.4	B102GT60-913911-3
115	4 1/2"	10*12	9*14	3FOG	35	9.7	21.3	B115GT60-9141012-3
115	4 1/2"	6*13	9*16	3FOG	35	9.7	21.3	B115GT60-916613-3
127	5"	10*14	9*16	3FOG	35	12.7	27.9	B127GT60-9161014-3
140	5 1/2"	10*14	9*16	3FOG	35	13.5	29.7	B140GT60-9161014-3
152	6"	12*14	9*16	3FOG	35	15.5	34.1	B152GT60-9161214-3

RETRAC



92	3 5/8"	6*12	8*14	4FOG	35	6.1	13.4	B92GT60-DR814612-4
102	4"	9*11	9*13	3FOG	35	7.3	16.1	B102GT60-R913911-3
115	4 1/2"	10*12	9*14	3FOG	35	9.9	21.8	B115GT60-R9141012-3
115	4 1/2"	6*13	9*16	3FOG	35	9.9	21.8	B115GT60-R916613-3
127	5"	10*14	9*16	3FOG	35	13.5	29.7	B127GT60-R9161014-3
140	5 1/2"	10*14	9*16	3FOG	35	16.5	36.3	B140GT60-R9161014-3
152	6"	12*14	9*16	3FOG	35	19.5	42.9	B152GT60-R9161214-3



- **Long Hole Drilling**

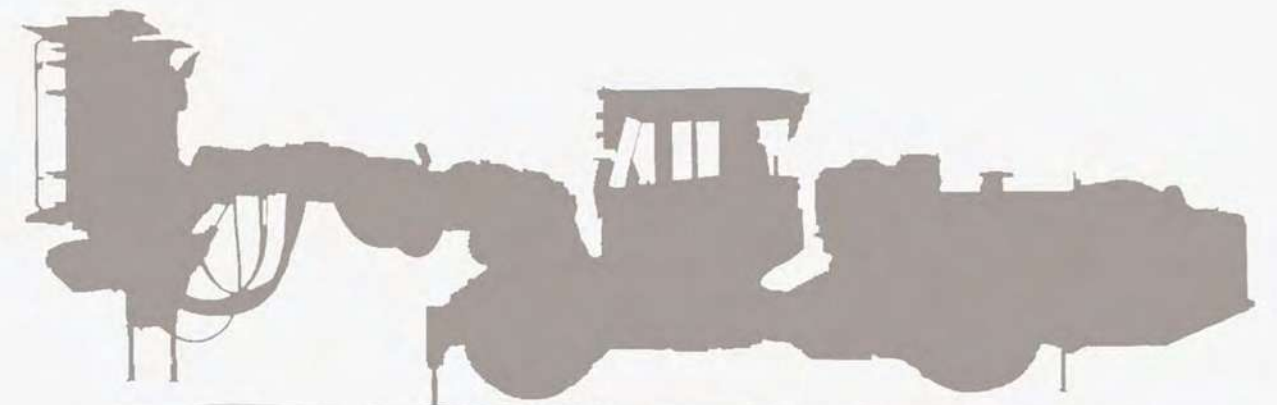



Long Hole Drilling



Long hole drilling string

Drill rod and Guide tube

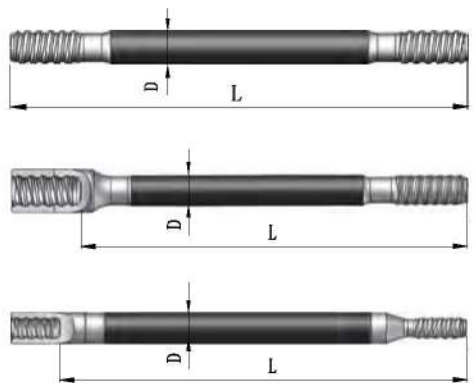
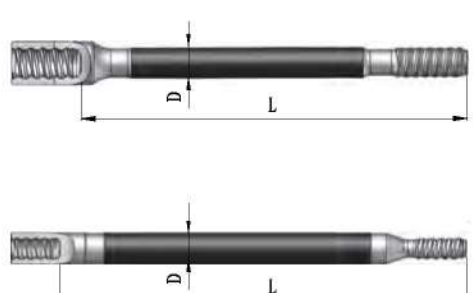
Products	Length			Weight		Part number
	MM	FT	IN	KG	LB	
R32 and T35 	1830	6'		16	35.2	GR32-D45-R32-1830
	915	3'		5.8	12.8	MFR32-D32-R32-915
	1220	4'		7.5	16.5	MFR32-D32-R32-1220
	1525	5'		9.5	20.9	MFR32-D32-R32-1525
	1830	6'		10.5	23.1	MFR32-D32-R32-1830
	915	3'		4.8	10.6	MMR32-D32-R32-915
	1220	4'		6.5	14.3	MMR32-D32-R32-1220
	1525	5'		8.7	19.2	MMR32-D32-R32-1525
	1830	6'		10	22	MMR32-D32-R32-1830
	1830	6'		16	35.2	MFT35-D38-T35-1830
T38, T45 and T51 	1830	6'		18	39.6	GT38-D56-T38-1830
	1830	6'		28	61.6	GT45-D64-T45-1830
	1830	6'		40	88	GT51-D76-T51-1830
	1220	4'		11	24.2	MFT38-D38-T38-1220
	1525	5'		13.5	29.7	MFT38-D38-T38-1525
	1830	6'		16	35.2	MFT38-D38-T38-1830
	1220	4'		14	30.8	MFT45-D45-T45-1220
	1525	5'		19	41.8	MFT45-D45-T45-1525
	1830	6'		23	50.6	MFT45-D45-T45-1830
	1525	5'		25	55	MFT51-D51-T51-1525
1830	6'		27	59.4	MFT51-D51-T51-1830	



Long Hole Drilling

Products	Length			Weight		Part number
	MM	FT	IN	KG	LB	
T45, ST58 and ST68 Drill tube 	1525	5'		28	61.6	DT45-D64-T45-1525
	1830	6'		32	70.4	DT45-D64-T45-1830
	1525	5'		33	72.6	DST58-D76-ST58-1525
	1830	6'		41	90.2	DST58-D76-ST58-1830
	1525	5'		40	88	DST68-D86-ST68-1525
	1830	6'		47	103.4	DST68-D86-ST68-1830



Long Hole Drilling

R32 and T35 drill bit

Diameter		Button		Flushing	Angle (°)	Weight		Part Number
MM	IN	Front	Gauge			KG	LB	



51	2"	3*9	6*10	3F1G	35	1	2.2	B51R32-61039-3
57	2 1/4"	3*10	6*11	3F1G	35	1.2	2.6	B57R32-611310-3
64	2 1/2"	3*11	6*12	3F1G	35	1.6	3.5	B64R32-612311-3
64	2 1/2"	3*11	6*12	3F1G	35	1.6	3.5	B64T35-612311-3
64	2 1/2"	4*10	8*11	2F1G	35	1.6	3.5	B64R32-811410-2
76	3"	4*12	8*12	2F1G	35	2.4	5.3	B76R32-812412-2
76	3"	5*11	8*12	4FOG	35	2.6	5.7	B76R32-812511-4

RETRAC



51	2"	3*9	6*10	3F1G	35	1.2	2.6	B51R32-R61039-3
51	2"	3*9	6*10	3F1G	35	1	2.2	B51T35-R61039-3
57	2 1/4"	3*10	6*11	3F1G	35	1.2	2.6	B57T35-R611310-3
64	2 1/2"	3*11	6*12	3F1G	35	1.6	3.5	B64R32-R612311-3
64	2 1/2"	4*10	8*11	2F1G	35	1.8	4	B64R32-R811410-2
76	3"	4*12	8*12	2F1G	35	3.5	7.7	B76R32-R812412-2
76	3"	5*11	8*12	4FOG	35	2.6	5.7	B76R32-R812511-4



Long Hole Drilling

T38 drill bit

Diameter		Button		Flushing	Angle (°)	Weight		Part Number
MM	IN	Front	Gauge			KG	LB	



64	2 1/2"	3*11	6*12	3F1G	35	1.6	3.5	B64T38-612311-3
64	2 1/2"	4*10	8*11	2F1G	35	1.6	3.5	B64T38-811410-2
76	3"	3*11	6*12	3F1G	35	2.4	5.3	B76T38-612311-3
76	3"	4*12	8*12	2F1G	35	2.4	5.3	B76T38-812412-2
76	3"	5*11	8*12	4FOG	35	2.6	5.7	B76T38-812511-4
76	3"	6*10	8*11	2F1G	35	2.4	5.3	B76T38-811610-2
89	3 1/2"	5*12	8*12	4FOG	35	3	6.6	B89T38-812512-4

RETRAC



64	2 1/2"	3*11	6*12	3F1G	35	1.8	4	B64T38-R612311-3
64	2 1/2"	4*10	8*11	2F1G	35	1.8	4	B64T38-R811410-2
76	3"	3*11	6*12	3F1G	35	3.5	7.7	B76T38-R612311-3
76	3"	4*12	8*12	2F1G	35	3.5	7.7	B76T38-R812412-2
76	3"	5*11	8*12	4FOG	35	3.5	7.7	B76T38-R812511-4
76	3"	6*10	8*11	2F1G	35	3	6.6	B76T38-R811610-2
89	3 1/2"	5*12	8*12	4FOG	35	4	8.8	B89T38-R812512-4



Long Hole Drilling

T45 drill bit

Diameter		Button		Flushing	Angle (°)	Weight		Part Number
MM	IN	Front	Gauge			KG	LB	



76	3"	5*11	8*12	4FOG	35	2.4	5.3	B76T45-812511-4
76	3"	6*10	8*11	2FIG	35	2.4	5.3	B76T45-811610-2
89	3 1/2"	5*13	8*13	4FOG	35	3.2	7	B89T45-813513-4
89	3 1/2"	6*10	9*11	3FIG	35	3.5	7	B89T45-911610-3
102	4"	9*11	9*13	3FOG	35	4.6	10.4	B102T45-913911-3

RETRAC



76	3"	5*11	8*12	4FOG	35	3	6.6	B76T45-R812511-4
76	3"	6*10	8*11	2FIG	35	3	6.6	B76T45-R811610-2
89	3 1/2"	5*13	8*13	4FOG	35	4	8.8	B89T45-R813513-4
89	3 1/2"	6*10	9*11	3FIG	35	4.6	10.1	B89T45-R911610-3
102	4"	9*11	9*13	3FOG	35	7	15.4	B102T45-R913911-3



Long Hole Drilling

T51 drill bit

Diameter		Button		Flushing	Angle (°)	Weight		Part Number
MM	IN	Front	Gauge			KG	LB	



89	3 1/2"	5*13	8*13	4FOG	35	3.6	7.9	B89T51-D813513-4
89	3 1/2"	6*10	9*11	3FIG	35	3.5	7	B89T51-911610-3
102	4"	6*12	9*12	3FIG	35	4.6	10.4	B102T51-912612-3
102	4"	9*11	9*13	3FOG	35	4.6	10.4	B102T51-913911-3
115	4 1/2"	10*12	9*14	3FOG	35	6	13.2	B115T51-9141012-3
127	5"	10*13	9*14	3FOG	35	6.6	14.5	B127T51-9141013-3

RETRAC



89	3 1/2"	5*13	8*13	4FOG	35	4.5	9.9	B89T51-DR813513-4
89	3 1/2"	6*10	9*11	3FIG	35	4.6	10.1	B89T51-R911610-3
102	4"	6*12	9*12	3FIG	35	7	15.4	B102T51-R912612-3
102	4"	9*11	9*13	3FOG	35	7	15.4	B102T51-R913911-3
115	4 1/2"	10*12	9*14	3FOG	35	8.5	18.7	B115T51-R9141012-3
127	5"	10*13	9*14	3FOG	35	12	26.4	B127T51-R9141013-3



Long Hole Drilling

ST58 and ST68 drill bit

Diameter		Button		Flushing	Angle (°)	Weight		Part Number
MM	IN	Front	Gauge			KG	LB	



89	3 1/2"	6*12	8*12	4FOG	35	4	8.8	B89ST58-D812612-4
89	3 1/2"	6*12	8*14	2FOG	35	4.5	9.9	B89ST58-814612-2
102	4"	5*14	8*16	2FOG	35	5.2	11.4	B102ST68-816514-2
102	4"	8*12	10*12	4FOG	35	5.2	11.4	B102ST68-D1012812-4
115	4 1/2"	8*14	10*14	4FOG	35	5.9	13	B115ST68-D1014814-4

RETRAC



89	3 1/2"	6*12	8*12	4FOG	35	4.5	9.9	B89ST58-DR812612-4
102	4"	8*12	10*12	4FOG	35	5.5	12.1	B102ST68-DR1012812-4
115	4 1/2"	8*14	10*14	4FOG	35	5.9	16.5	B115ST68-DR1014814-4



Long Hole Drilling

R32, T38, T45, T51, ST58 and ST68 reaming tools

Diameter		Button		Flushing	Angle (°)	Weight		Part Number
MM	IN	Front	Gauge			KG	LB	



89	3 1/2"	4*10	8*12	4	35	4	8.8	RB89/43R32
102	4"	3*10	12*13	4	35	5.2	11.4	RB102/43R32
89	3 1/2"	4*10	8*12	4	35	4	8.8	RB89/48T38
102	4"	3*10	12*13	4	35	5.2	11.4	RB102/48T38
127	5"	3*14	9*14	4	35	6.4	13.6	RB127/48T38
127	5"	3*14	9*14	4	35	6.6	14.5	RB127/48T45
152	6"	7*14	8*14	4	35	15	33	RB152/76T45
152	6"	7*14	8*14	4	35	15	33	RB152/89T45
152	6"	7*14	8*14	4	35	15	33	RB152/76T51
152	6"	7*14	8*14	4	35	15	33	RB152/89T51
152	6"	7*14	8*14	4	35	15	33	RB152/89ST58
152	6"	7*14	8*14	4	35	15	33	RB152/89ST68

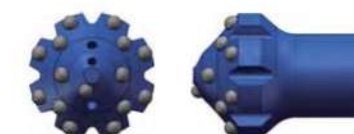

127	5"	1*13	18*13	4	35	5.2	11.4	DB127T38
127	5"	1*13	18*13	4	35	6.6	14.5	DB127T45
152	6"	2*14	18*14	4	35	9.9	21.8	DB152T45
152	6"	2*14	18*14	4	35	9.9	21.8	DB152T51
152	6"	2*14	18*14	4	35	10.4	22.9	DB152ST58
152	6"	2*14	18*14	4	35	11.8	26	DB152ST68



- **Shank Adapter**

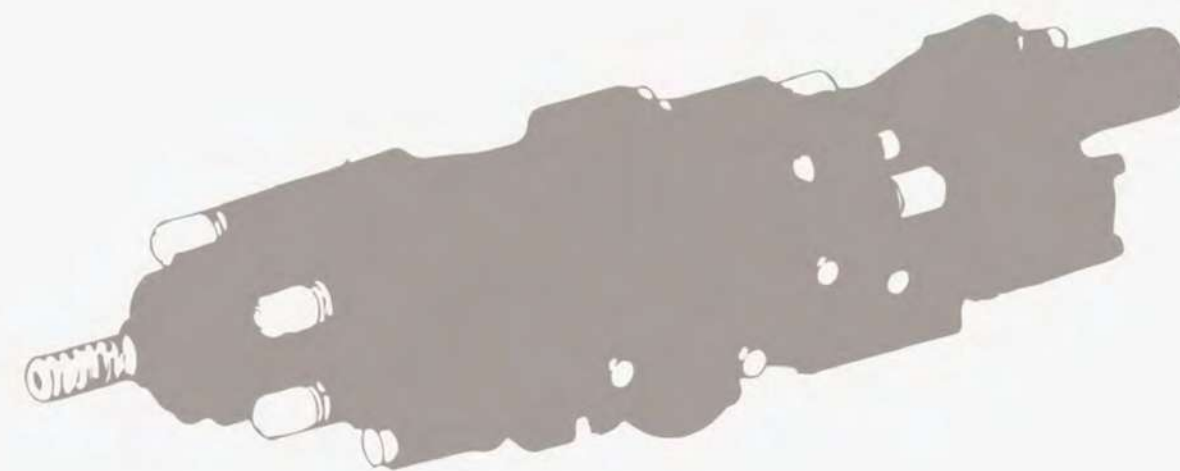



Shank adapter

Sandvik-Tamrock-1



Shank adapter

Sandvik-Tamrock-2

Products	Thread	Diameter (mm)	Length (mm)	Weight (Kg)	Part Number
<p>Sandvik-Tamrock HL300</p>	R28	45	187	1.7	HL300-45R28-187
<p>Sandvik-Tamrock HL500/HL510</p>	R38	45	500	5.4	HL500-45R38-500
	T38	45	550	5.9	HL500-45T38-550
	T45	45	550	6.2	HL500-45T45-550
	R38	38	460	4.1	HL500-38R38-460
	T38	38	460	4.1	HL500-38T38-460
	T38	38	550	4.3	HL500-38T38-550
<p>Sandvik-Tamrock HL600/HL600S</p>	R32	45	600	5.8	HL600-45R32-600
	R38	45	525	5.6	HL600-45R38-525
	T38	45	525	5.6	HL600-45T38-525
	T38	45	600	6.0	HL600-45T38-600
	T45	45	525	5.8	HL600-45T45-525
	T45	45	600	6.4	HL600-45T45-600
<p>Sandvik-Tamrock HL700/HL800</p>	T38	45	600	7.0	HL700-45T38-600
	T38	52	600	8.4	HL700-52T38-600
	T45	45	600	7.2	HL700-45T45-600
	T45	52	600	8.8	HL700-52T45-600
	T51	52	600	9.2	HL700-52T51-600
<p>Sandvik-Tamrock HL850S</p>	T45	52	670	9.2	HL850S-52T45-670

Products	Thread	Diameter (mm)	Length (mm)	Weight (Kg)	Part Number
<p>Sandvik-Tamrock HL1000</p>	T45	52	670	10.0	HL1000-52T45-670
	GT60	60	670	13.0	HL1000-60GT60-670
	T51	60	670	12.0	HL1000-60T51-670
	T51	52	670	10.2	HL1000-52T51-670
	T51	52	590	9.3	HL1000-52T51-590
<p>Sandvik-Tamrock HL1000</p>	ST68	80	640	17.0	HL1000-80ST68-640
<p>Sandvik-Tamrock HL1500</p>	GT60	80	760	21.0	HL1500-80GT60-760
	ST68	80	635	18.5	HL1500-80ST68-635
<p>Sandvik-Tamrock HL1500</p>	T51	51	710	11.0	HL1500-51T51-710
<p>Sandvik-Tamrock HL1500T/HL500 PE</p>	GT60	65	760	17.0	HL1500PE-65GT60-760
	T51	65	760	16.0	HL1500PE-65T51-760
<p>Sandvik-Tamrock HL1500T/HL500 PE</p>	ST68	90	635	22.0	HL1500PE-90ST68-635
	ST58	90	635	22.0	HL1500PE-90ST58-635



Shank adapter





Sandvik-Tamrock-3



Shank adapter

Atlas Copco-1





Products	Thread	Diameter (mm)	Length (mm)	Weight (Kg)	Part Number
Sandvik-Tamrock HLX5 	R38	45	500	5.2	HLX5-45R38-500
	T38	45	500	5.2	HLX5-45T38-500
	T45	45	500	5.2	HLX5-45T45-500
Sandvik-Tamrock RD314 	R32	38	410	3.2	RD314-38R32-410
Sandvik-Tamrock RD314 	R32	45	205	2.0	RD314-45FR32-205
Sandvik-Tamrock RD525/RD520-PE 	T38	45	745	7.2	RD525PE-45T38-745
	T35	45	745	7.2	RD525PE-45T35-745
Sandvik-Tamrock RD525/RD520 	T45	45	525	5.6	RD525-45T45-525
Sandvik-Tamrock RD900PE 	GT60	65	670	15.0	RD900PE-65GT60-670

Products	Thread	Diameter (mm)	Length (mm)	Weight (Kg)	Part Number
Atlas Copco COP1238 COP1038 COP1036 	T38	38	500	4.2	COP1238-38T38-500
	R38	38	500	4.2	COP1238-38R38-500
	R32	38	485	4.0	COP1238-38R32-485
Atlas Copco COP1238 COP1038 COP1036 	T45	45	575	5.8	COP1238-45T45-575
	R38	38	575	5.2	COP1238-38R38-575
	R32	38	500	4.0	COP1238-38R32-500
	T38	45	575	5.4	COP1238-45T38-575
Atlas Copco COP1435 	R32	35	500	3.0	COP1435-35R32-500
Atlas Copco COP1240 COP1640 	T38	52	565	6.5	COP1240-52T38-565
Atlas Copco COP1840 	T45	52	565	7.2	COP1840-52T45-565
	T51	52	565	7.5	COP1840-52T51-565

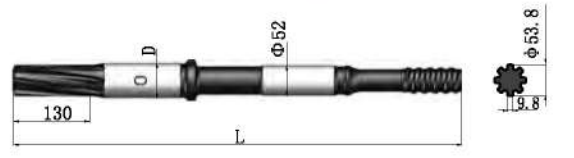

Shank adapter

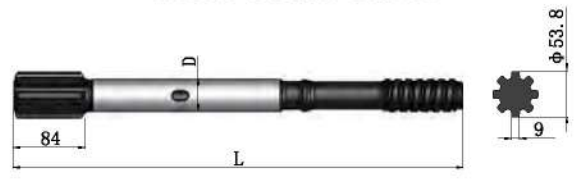

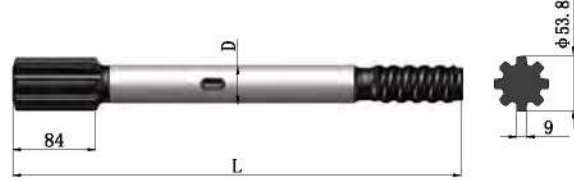
Atlas Copco-2

Products	Thread	Diameter (mm)	Length (mm)	Weight (Kg)	Part Number
Atlas Copco COP1840EX/1640EX/1240EX COP2150EX/2540EX/2550EX 	T38	60	770	9.9	COP1840EX-60T38-770
	T45	60	770	10.8	COP1840EX-60T45-770
	T51	60	770	10.9	COP1840EX-60T51-770
Atlas Copco COP1440 COP1550 COP1838 	T38	52	525	6.0	COP1838-52T38-525
	T45	52	525	6.7	COP1838-52T45-525
	T51	52	525	6.8	COP1838-52T51-525
Atlas Copco COP1440 COP1550 COP1838 COP1638 COP2238 	T38	38	525	4.0	COP1838-38T38-525
	R32	38	525	5.7	COP1838-38R32-525
Atlas Copco COP1440 COP1550 COP1838HD COP1638 COP2238 	T38	38	435	4.0	COP1838HD-38T38-435
	R38	38	435	4.0	COP1838HD-38R38-435
	R32	38	435	4.0	COP1838HD-38R32-435
Atlas Copco COP1638 COP1838AW 	T38	38	455	4.0	COP1838AW-38T38-455
	R38	38	455	4.0	COP1838AW-38R38-455

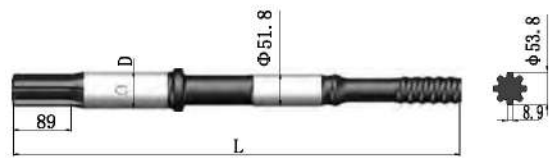
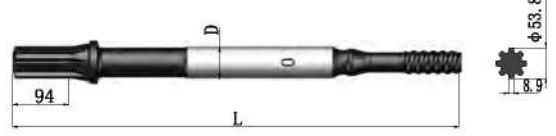
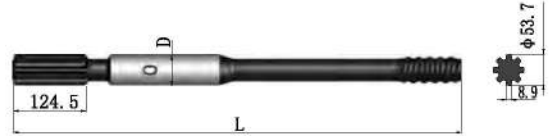

Shank adapter

Atlas Copco-3

Products	Thread	Diameter (mm)	Length (mm)	Weight (Kg)	Part Number
Atlas Copco COP1838EX 	T45	60	730	10.4	COP1838EX-60T45-730
	T51	60	730	10.2	COP1838EX-60T51-730
Atlas Copco COP1838MUX/HUX 	T38	52	730	10.0	COP1838MUX-52T38-730
Atlas Copco COP2150 COP2550 	T45	52	770	9.5	COP2150-52T45-770
	T51	52	770	10.0	COP2150-52T51-770
Atlas Copco COP2150 COP2550 	T45	52	770	9.2	COP2150-52T45-770
	T51	52	770	8.5	COP2150-52T51-770
Atlas Copco COP2160 COP2560 	T45	60	770	10.9	COP2160-60T45-770
	T51	60	770	11.0	COP2160-60T51-770



Shank adapter

Atlas Copco-4

Products	Thread	Diameter (mm)	Length (mm)	Weight (Kg)	Part Number
Atlas Copco COP2160EX COP2560EX	T45	63	770	13.2	COP2160EX-63T45-770
	T51	63	770	13.3	COP2160EX-63T51-770
Atlas Copco COP3038	TC42	45	435	4.8	COP3038-45TC42-435
					
Atlas Copco COP3060MEX	GT60	60	840	16.6	COP3060MEX-60GT60-840
	T51	60	840	15.8	COP3060MEX-60T51-840
	TWIZ60	60	840	17.0	COP3060MEX-60TZ60-840
Atlas Copco COP3060MUX	ST58	90	745	23.7	COP3060MUX-90ST58-745
					
Atlas Copco COP4050MUX	ST68	90	835	26.9	COP3060MUX-90ST68-835
					



Shank adapter





Atlas Copco-5

Products	Thread	Diameter (mm)	Length (mm)	Weight (Kg)	Part Number
Atlas Copco COP4050ME	GT60	70	700	14.7	COP4050ME-70GT60-700
	T51	52	605	8.9	COP4050ME-52T51-605
Atlas Copco COP1132	R32	35	410	2.5	COP1132-35R32-410
					
Atlas Copco RD18S	T45	52	654	6.2	RD18S-52T45-654
	T51	52	654	6.3	RD18S-52T51-654
Atlas Copco RD22U	T45	45	525	5.4	RD22U-45T45-525
					
Atlas Copco BBC54 BBC120	T38	38	390	3.1	BBC120-38T38-390
					
Atlas Copco MD20	T38	38	470	4.4	MD20-38T38-470
	R38	38	470	4.4	MD20-38R38-470



Shank adapter

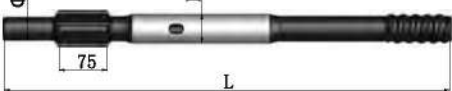





Furukawa-1

Products	Thread	Diameter (mm)	Length (mm)	Weight (Kg)	Part Number
	T38	45	815	9.3	HD709RP-45T38-815
	T45	45	785	9.8	HD709RP-45T45-785
	T45	45	815	9.9	HD709RP-45T45-815
	T51	51	885	13.0	HD712RP-51T38-885
	T45	51	885	12.5	HD712RP-51T45-885
	T45	51	787	10.0	HD712RP-51T45-787
	T51	58	885	15.8	HD715RP-58T51-885
	T38	45	620	6.2	HD609-45T38-620
	T38	45	690	6.4	HD609-45T38-690
	T45	45	620	6.3	HD609-45T45-620
	T45	45	690	6.9	HD609-45T45-690
	T45	51	670	8.5	HD612-51T45-670
	T45	51	710	9.1	HD612-51T45-710
	T51	51	670	8.7	HD612-51T51-670
	T51	51	710	9.3	HD612-51T51-710
	T45	51	750	9.2	HD612-51T45-750
	T51	51	750	9.4	HD612-51T51-750

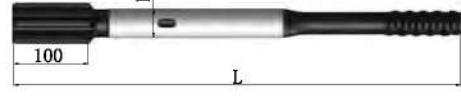

Shank adapter

Furukawa-2

Products	Thread	Diameter (mm)	Length (mm)	Weight (Kg)	Part Number
	T45	58	700	10.6	HD615-58T45-700
	T51	58	700	10.8	HD615-58T51-700
	T51	58	880	13.0	HD615-58T51-880
	T38	45	590	6.2	HD709-45T38-590
	T38	45	620	6.6	HD709-45T38-620
	T45	45	590	6.5	HD709-45T45-590
	T45	45	620	6.8	HD709-45T45-620
	T45	51	590	8.4	HD712-51T45-590
	T45	51	790	9.7	HD712-51T45-790
	T51	51	590	8.8	HD712-51T51-590
	T51	51	790	9.9	HD712-51T51-790
	T45	45	654	6.6	HD300-45T45-654
	T51	58	790	12.0	HD715-58T51-790
	R32	45	380	4.2	PD200-45R32-380
	T38	45	380	3.6	PD200-45T38-380



Shank adapter

Montabert-1

Products	Thread	Diameter (mm)	Length (mm)	Weight (Kg)	Part Number
<p>Montabert HC20</p>	R32	45	287	2.9	HC20-45R32-287
<p>Montabert HC25</p>	R28	45	200	2.1	HC25-45R28F-200
	R32	45	200	1.9	HC25-45R32F-200 R
	R32	45	200	1.9	HC25-45R32F-200
	R32	45	272	2.8	HC25-45R32F-272 R
					R=Right hand
<p>Montabert HC25</p>	R32	45	340	3.1	HC25-45R32-340
<p>Montabert HC28</p>	R25	45	272	2.8	HC28-45R25F-272
	R32	45	272	3.0	HC28-45R32F-272
<p>Montabert HC28</p>	T38	45	385	3.8	HC28-45T38-385
	R38	45	385	3.8	HC28-45R38-385



Shank adapter







Montabert-2

Products	Thread	Diameter (mm)	Length (mm)	Weight (Kg)	Part Number
<p>Montabert HC40 HC50</p>	R38	38	445	4.0	HC40-38R38-445
	T38	38	445	4.0	HC40-38T38-445
<p>Montabert HC50</p>	R38	45	390	4.0	HC50-45R38-390
<p>Montabert HC95R 95RLM 95LHRP</p>	T38	45	500	5.7	HC95R-45T38-500
	T38	45	500	5.7	HC95RLM-45T38-500
	T38	45	503	5.7	HC95LHRP-45T38-503
	T45	45	515	5.8	HC95R-45T45-515
<p>Montabert HC25</p>	H19F	45	220	2.4	HC25-45H19F-220
<p>Montabert HC95SA</p>	T38	45	468	5.5	HC95SA-45T38-468



Shank adapter





Montabert-3

Products	Thread	Diameter (mm)	Length (mm)	Weight (Kg)	Part Number
Montabert HC109 	T38	38	500	4.5	HC109-38T38-500
	T38	38	440	4.0	HC109-38T38-440
Montabert HC109 	T38	45	490	5.2	HC109-45T38-490
	T38	45	460	4.9	HC109-45T38-460
	T45	45	490	5.2	HC109-45T45-490
Montabert HC109RP HC80RP/105RP/107RP/108RP 	T45	45	670	7.5	HC109RP-45T45-670
Montabert HC110 	T38	45	415	4.2	HC110-45T38-415
	T38	45	425	4.2	HC110-45T38-425
Montabert HC120RP HC150RP/155RP/158RP 	T45	51	670	8.8	HC120RP-51T45-670
	T51	51	670	8.8	HC120RP-51T51-670
Montabert HC80 HC90 HC105 	R38	38	440	3.9	HC80-38R38-440
	T38	38	440	3.9	HC80-38T38-440
	R32	38	440	3.7	HC80-38R32-440



Shank adapter

Ingersoll Rand-1

Products	Thread	Diameter (mm)	Length (mm)	Weight (Kg)	Part Number
Ingersoll Rand YH50 	R38	38	440	3.7	YH50-38R38-440
Ingersoll Rand YH50RP 	T38	38	560	4.5	YH50RP-38T38-560
Ingersoll Rand YH65 	T38	45	500	5.0	YH65-45T38-500
	T45	45	500	5.0	YH65-45T45-500
	T45	45	610	6.1	YH65-45T45-610
Ingersoll Rand YH65RP 	T38	45	700	7.8	YH65RP-45T38-700
	T45	45	700	7.9	YH65RP-45T45-700
Ingersoll Rand YH70 	T38	45	580	6.0	YH70-45T38-580
	T45	51	610	6.7	YH70-51T45-610



Shank adapter

Ingersoll Rand-2



Products	Thread	Diameter (mm)	Length (mm)	Weight (Kg)	Part Number
Ingersoll Rand YH70RP 	T45	45	820	8.5	YH70RP-45T45-820
Ingersoll Rand YH80A 	T45	51	500	5.7	YH80A-51T45-500
Ingersoll Rand YH95 	T45 T51 T51	51 51 51	625 625 515	6.9 6.9 5.7	YH95-51T45-625 YH95-51T51-625 YH95-51T45-515
Ingersoll Rand YH95RP 	T51 T51	51 51	840 515	9.3 5.7	YH95RP-51T51-840 YH95RP-51T51-515
Ingersoll Rand YH135A 	T51	55	728	8.0	YH135A-55T51-728

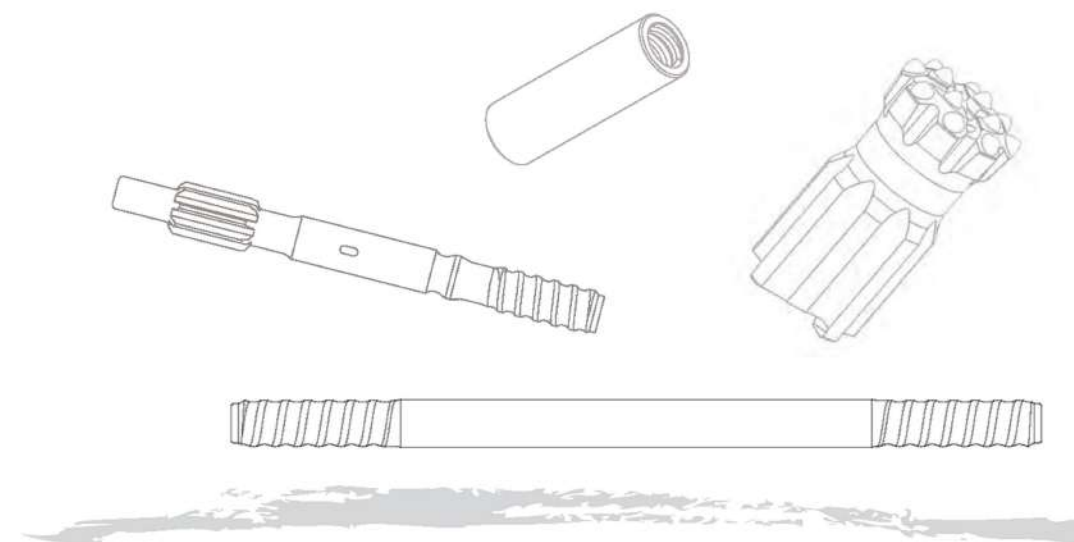



Guide for use of Rock Drilling Tools

Top hammer rock drilling tools include drill bit, drill rod, shank adapter and coupling sleeve. Correct selection and use of rock drilling tools is one of the best measures to prolong the service life. It not only reduces the consumption of rock drilling tools, but also enables users to obtain good economic benefits in rock drilling and blasting engineering.

1. Factors needing attention in the correct selection of rock drilling tools

1.1 Based on the rock formation and construction conditions, the rock drilling and blasting method shall be correctly selected to determine the type selection of rock drilling tools, including specification and model, drill rod length, connection mode, drill bit design and diameter, etc.

1.2 When selecting rock drilling tools, please be familiar with the technical performance of the rock drilling equipment you own or will own.

1.3 When the selected rock drilling tools are abnormally broken or damaged, the status of the drilling equipment should be checked in time and the wearing parts with serious wear should be replaced; At the same time, adjust the rock drilling construction method and select the appropriate rock drilling tools. For example, change the specification and model of the drill rod and the design of the drill bit.

1.4 Select the rock drilling tools manufacturer and brand according to the drilling equipment and drilling conditions to obtain good cost performance. With the minimum investment, to obtain the maximum use benefit.

2. Precautions when using rock drilling tools

2.1 Before using any rock drilling tools, check whether the water flushing hole is unblocked.

Never use the tools with a blocked water hole, as insufficient flushing and cooling may lead to excessive wear and premature failure.

2.2 Check the appearance of the rock drilling tools. For example, whether there are defects on the surface that affect the use, and whether the straightness of the drill rod is good. Some of these factors are caused by loading and transporting.

2.3 Check the fitting between the rock drilling tools and the rock drill (drifter) and the connecting parts. Sometimes the early failure of the rock drilling tools is caused by the wear of the accessories of the rock drill. If the bushing of rock drill is seriously worn, on the one hand, it will cause the drill tail to bear eccentric impact load and make it break early. On the other hand, the internal piston, spline sleeve and other parts of the rock drill will also be damaged.

2.4 Skilled operators can well adjust the working state of rock drilling equipment during hole opening and drilling. Such as giving low impact force, low propulsion force, low revolution, etc. when opening the hole; Ensuring the straightness of tools and blast holes during rock drilling.

2.5 When drilling blast holes in rocks with complex geological conditions, it is best to use guide tubes and retrac bits to prevent unnecessary loss of rock drilling tools caused by hole



deviation or sticking, and damage to the surface of the drill rod when handling the sticking, which greatly reduces the service life of the surface damaged drill rod.

2.6 Pay attention to the wear of the carbide of the drill bit, and regrind or replace it in time to avoid blunt drilling, otherwise the service life of the drill rod, shank adapter and coupling sleeve will be greatly reduced.

2.7 The rock drilling tools should be lubricated well during use, and there should be sufficient air and water supply during use (rock drilling equipment has certain requirements for air pressure, water pressure and flow). On the one hand, it can help you improve the speed of rock drilling; On the other hand, it can prevent the temperature rise during drilling, which will change the material properties of the drill tool and cause early failure.

2.8 Rock drilling tools are rock drilling tools. Do not use them as crowbars to reduce their use value.

2.9 Do not hammer the rock drilling tools with heavy objects and make improper marks on them. The scars and striking marks on the surface will cause early failure.

2.10 During drilling operations, oblique drilling and empty drilling shall be avoided.

3. Classification of rock drilling tools

According to the use characteristics, rock drilling tools can be divided into three categories: open-pit rock drilling, tunneling and drifting and underground production drilling.

3.1 Open-pit rock drilling--- It is mainly used for open-pit construction and open-pit mining.

One drill rig can hold 7 drill rods, with a drilling diameter of 51 ~ 115mm and a drilling depth of 20 ~ 30m. Common specifications and models are T38, T45, T51, GT60, and the length of drill rods are 3.05m, 3.66m, 4.265m, etc.

3.2 Tunneling and drifting--- It is mainly used for tunneling. Only one drill rod is used when drilling, with a drilling diameter of 41 ~ 89mm. Common specifications and models are T38H35R32, R38H35R32, R38H32R32, etc, and the length of drill rods are 2.475m, 3.7m, 4.305m, 4.915m, 5.525m, 6.4m, etc.

3.3 Underground production drilling--- It is mainly used for underground mining production drilling. One drill rig can hold 20-30 drill rods, with a drilling diameter of 41 ~ 152mm and a drilling depth of 20 ~ 30m, maximum 40m. Common specifications and models are H32, D32, T38, T45, T51, ST58, ST68, and the length of drill rods are 1.22m, 1.525m, 1.83m, etc.

4. Failure analysis of rock drilling tools

The rock drilling tools are used in conjunction with the rock drill. In the actual rock drilling process, in addition to its own factors, the product quality/performance is also directly related to the state of the rock drill, geological conditions, rock tools selection and operation. For this reason, the failure of rock drilling tools can be divided into normal failure (failure with a certain service life) and early failure. Early failure can be divided into failure caused by unqualified product quality and caused by improper use.



4.1 Button bit early failure analysis

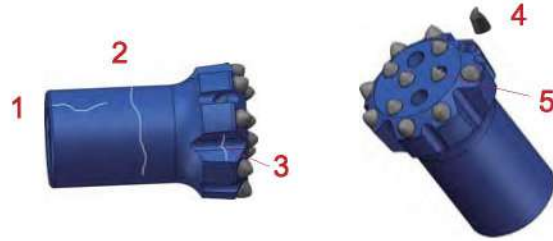

Failures	Possible cause	Recommended solution
Area 1: Longitudinal crack on skirt	Worn and/or loose threads	Tighten the threads before starting the percussion. Maintain proper alignment of the drill string, do not mix component brands, replace worn out components.
	Mismatched threads	Make sure the threads and connections are correct.
Area 2: Transversal crack on skirt	Processing or material defects	Check out with manufacturer analysis.
	Mismatched, Worn and/or loose threads	Tighten the threads before starting the percussion. Maintain proper alignment of the drill string, do not mix component brands, replace worn out components.
	Excessive rotation when stuck	Adjust operations
Area 3: Crack around gauge buttons	Processing or material defects	Check out with manufacturer analysis.
Area 4: Gauge Button loose	Tightening strength not enough	Check out with manufacturer analysis.
	Inadequate flushing	Choose proper rock drilling tools and Use water as flushing and cooling agent.
Area 5: Button cracked & Button chipped	Facing metalical materials	Foreign matters in the hole, such as steel bars and other metal products, are encountered during drilling.
	Overdrilled buttons	Reduce intervals between grinding and frequently inspect buttons for snakeskin.
	Processing or material defects	Check out with manufacturer analysis.



4.2 Early failure and failure causes of threaded drill rod



Failures	Possible cause	Recommended solution
Area 1: Recess	Stress concentration caused by machining defects	Check out with manufacturer analysis.
Area 2: Breakage across shaft	Material defects	Check out with manufacturer analysis.
	Steel surface compromised by dents from Improper transportation, storage and use	Employ proper care and handling of proper transportation, storage and use.
Area 3: Breakage across coupling ends or behind threads	Hole deviation	Employ straight hole drilling equipment (e.g. bits with drop center face design or retrac body)
	Worn threads	Avoid mixed new and worn out threads.
	Misalignment of the feed in relation to the hole direction	Employ straight hole drilling equipment.
	Excessive feed force	Adjust feed pressure according to recommendations.
	The rotation speed too fast when withdrawing the tool (lifting the tool)	Adjust Rock Drill pressure.
	Excessive rotation while drilling with worn buttons	Following proper procedures for grinding.
	Drilling in broken material or through voids in the rock	Adjust percussion and feed pressures to rock conditions.
	Continued percussion when drill rods jam in void or seam	Use a drill with anti-jam features, reduce feed and percussion pressure.
	Steel surface compromised by dents from Improper transportation, storage and use	Employ proper care and handling of proper transportation, storage and use.



Maintenance and Troubleshooting

Area 4: Breakage across male end threads	Threads worn, broken or mismatched	Maintain proper alignment of the drill string, do not mix component brands, replace worn out components.
	Steel surface compromised by dents from Improper transportation, storage and use	Employ proper care and handling of proper transportation, storage and use.
	Stress concentration caused by machining defects, which is characterized by internal fatigue failure	Check out with manufacturer analysis.
Area 5: Chip broken off the male end	Bits threads worn, coupling threads or bridge wear	Replace worn out components.
	Direct impact on the end Unused impact energy fed back to the drill (empty drilling)	Loosen the connection using the removal wrench. Adjust percussion and feed pressures to rock conditions.
Area 6: Transversal crack across the female end	Hole deviation	Employ straight hole drilling equipment (e.g. bits with drop center face design or retrac body) Adjust feed pressure according to recommendations
	Improper feed force	Following proper procedures for grinding.
	Excessive rotation while drilling with worn buttons	Loosen the connection using the removal wrench and avoid direct impact on the thread surface.
	Steel surface compromised by dents from Improper transportation, storage and use(Stress concentration)	Maintain proper alignment of the drill string, do not mix component brands, replace worn out components.
Area 7: Chip broken off the female end	Threads worn, broken or mismatched	Replace worn out components. And do not mix worn out and new rock drilling tools.
	Mixed worn out and new rock drilling tools	Adjust feed pressure according to recommendations.
	Improper feed force	Make sure the threads are properly connected.
	Improper connection between the threads	Reduce intervals between grinding and frequently inspect buttons for snakeskin. Replace Overdrilled bits.
Area 3 and 7: Ablation pits or blueness on the surface of drill pipe threads	Overdrilled bits	Strengthen maintenance and repair, timely replace worn parts, and ensure the concentricity of rock drilling tools and holes.
	Poor lubrication or some contact of points and lines caused by thread fitting	



Maintenance and Troubleshooting

4.3 Early failure and failure causes of shank adapter

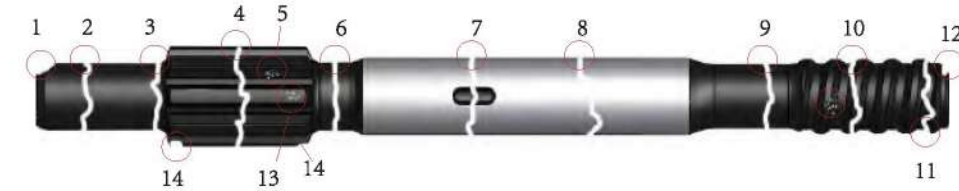

Failures	Possible cause	Recommended solution
Area 1: Chipped striking face	Misalignment due to worn bushings	Replace worn out components
	Damaged piston	Replace worn out components
	When replacing spare parts, hard objects are brought into the rock drill, and local forces are exerted during the impact process	Clean the hydraulic and lubrication system.
	Poor lubrication leads to high temperature adhesion on the contact surface and damage to the end face	Regularly maintain the lubrication system.
Area 2: Transversal crack on some 25mm from striking face	Drive chuck worn	Replace worn out components.
	Fatigue failure at water seal groove	Check out with manufacturer analysis.
Area 3: Breakage on top of spline shoulder	Poor lubrication	Regularly maintain the lubrication system.
	Excessive feed force	Adjust feed pressure according to recommendations
	The drive chuck or front bushing is broken, worn and deformed	Replace worn out components.
	Processing or material defects	Check out with manufacturer analysis.



Maintenance and Troubleshooting

Area 4: Breakage across splines	Drive chuck broken, worn and deformed	Replace worn out components.
	Excessive rotation torque	Following proper operations procedures
	Poor lubrication	Regularly maintain the lubrication system.
	Overdrilled bits	Reduce intervals between grinding and frequently inspect buttons for snakeskin. Replace Overdrilled bits.
	Improper feed force	Adjust feed pressure according to recommendations
Area 5: Pitting and galling on splines	Hard objects are brought into the rock drill, and local forces are exerted during the impact process	Clean the hydraulic and lubrication system.
	The rotation speed too fast when withdrawing the tool (lifting the tool)	Adjust Rock Drill feed pressure.
Area 6: Breakage on bottom of spline shoulder	The rotation speed too fast when withdrawing the tool (lifting the tool)	Adjust Rock Drill feed pressure.
Area 7: Breakage through flushing port	Stress concentration	Check out with manufacturer analysis.
	Erosion	Adequately neutralize flushing and cooling agent for erosion, evaluate proper storage practices. Check out with manufacturer analysis.
Area 8: Breakage across fronthead	Misalignment from worn front bushing	Replace worn out components.
	Lack of lubrication	Regularly maintain the lubrication system.
Area 9: Breakage above threads	Stress concentration caused by Processing defects	Check out with manufacturer analysis.
	Drilling deviation, and the non concentricity of drill rod, coupling sleeve and drill bit leads to stress concentration	Observe at any time. Once the hole deviates, adjust the operation in time or use appropriate rock drilling tools.
	Improper feed force	Adjust feed pressure according to recommendations.



Maintenance and Troubleshooting

	Threads worn, broken or mismatched	Maintain proper alignment of the drill string, do not mix component brands, replace worn out components.
	Poor lubrication, and there are ablation pits on the threads	Regularly maintain the lubrication system.
Area 10: Breakage across threads	Threads worn, broken or mismatched	Maintain proper alignment of the drill string, do not mix component brands, replace worn out components.
	Poor lubrication	Regularly maintain the lubrication system.
	Excessive occlusion	Avoid over tightening. If the connection cannot be loosened, check the factors that may cause the thread to be too tight: 1. Overdrilled bit 2. Wear or deformation of drill rod or coupling sleeve thread 3. Incorrect or too tight assembly 4. Insufficient lubrication
Area 11: Breakage in the front of the thread	Excessive feed force	Adjust feed pressure according to recommendations.
	Damaged drill rod	Replace drill rod
	Coupling threads worn, broken	Maintain proper alignment of the drill string, do not mix component brands, replace worn out components.



Maintenance and Troubleshooting

Area 9 and 11: Ablation pits or blueness on the thread surface	Overdrilled bits	Reduce intervals between grinding and frequently inspect buttons for snakeskin. Replace Overdrilled bits.
	Poor lubrication or local contact of points and lines caused by thread fitting	Strengthen maintenance and repair, timely replace worn parts, and ensure the concentricity of rock drilling tools and holes.
	Improper feed force	Adjust feed pressure according to recommendations.
Area 12: Chipped thread face	Poor contact between the end face of the shank adapter thread and the end face of the coupling sleeve or the connecting part of the drill rod	Replace the damaged or worn coupling sleeve or drill rod.
	The end of the drill rod (threaded connection) is damaged and continues to be used	Replace drill rod.
Area 13: Pitting and galling on splines	Lack of lubrication	Regularly maintain the lubrication system.
	Excessive rotation in soft or fragile rock formation	Adjust Rock Drill feed pressure.
Area 14: Excessive wear on top/bottom of spline shoulder	Front and back bushings are broken, worn and deformed.	Replace worn out components.
	Damaged piston	Replace worn out components.
	Excessive rotation when pushing or lifting	Adjust the operation or check the buffer system.
	Lack of lubrication	Regularly maintain the lubrication system.



Maintenance and Troubleshooting

4.4 Early failure and failure causes of coupling sleeve



Failures	Possible cause	Recommended solution
Area 1: Chipped , flared or cracked end	Threads worn, broken or mismatched	Maintain proper alignment of the drill string, do not mix component brands or new and worn parts, replace worn out components.
	Overheating of coupling	The maximum running temperature for couplings is 150° C (302° F). Use proper flushing media.
	Misalignment of the feed in relation to the hole direction	Employ straight hole drilling equipment (e.g. bits with drop center face design or retrac body).
	Starting percussion or rotation with end of the shank resting against the end of the coupling	Do not engage percussion or rotation if shank thread end is not aligned inside coupling.
Area 2: Longitudinal crack	Threads worn, broken or mismatched	Maintain proper alignment of the drill string, do not mix component brands, replace worn out components.
	Metal fatigue	Check out with manufacturer analysis.
	Steel surface compromised by dents or nicks	Avoid hammering on connection, use a breakout wrench to loosen joints, employ proper care and handling.



Maintenance and Troubleshooting



	Misalignment of the feed in relation to the hole direction	Employ straight hole drilling equipment (e.g. bits with drop center face design or retrac body).
	Percussion when reverse rotation	Avoid percussion while reverse rotation.
Area 3: Transversal crack	Misalignment of the feed in relation to the hole direction	Employ straight hole drilling equipment (e.g. bits with drop center face design or retrac body).
	Excessive rotation while drilling with worn buttons	Follow proper procedures for grinding.
	Metal fatigue	Check out with manufacturer analysis.
	Steel surface compromised by dents or nicks	Avoid hammering on connection, use a breakout wrench to loosen joints, employ proper care and handling.
	Threads worn, broken or mismatched	Maintain proper alignment of the drill string, do not mix component brands, replace worn out components.



**INDUSTRIAL AND ENGINEERING
TECHNOLOGY Co., Limited**

**Add: 8 Floor, China Hong Kong Tower,
8-12 Hennessy Road, Wan Chai, Hong
Kong**

**E-mail: business@iet-hongkong.com
WhatsApp +852 5473 6914**

Dear customers, as a supplier, we have developed and strictly control perfect technical documentation on material selection, processing technology and quality control of drilling tools products, and we are glad to be able to supply high-quality products for your use. At the same time, we also hope to provide the best service and use of high-quality drilling tools.